

CATEGORY	DESCRIPTION	P/N #
CONNECTOR	MINI USB 8PIN SINGLE-ROW	UB3083-11F10-0010

REV.	ECN NO	DESCRIPTION	REVISED	DATE
A01		NEW RELEASE	TANGHUI	2009.07.28

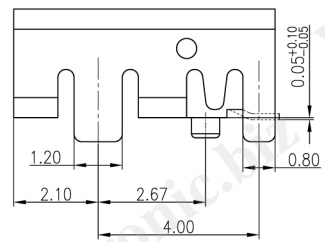

- SPECIFICATIONS:
- 1.VOLTAGE&CURRENT RATING: AC 5V&1A.
 - 2.DIELECTRIC WITHSTANDING VOLTAGE:AC 100V FOR 1 MINUTE.
 - 3.INSULATION RESISTANCE: 100 MΩ MIN. AT DC 500V.
 - 4.CONTACT RESISTANCE: 50 mΩ MAX.
 - 5.CONTACT INSERTION FORCE:35N MAX.
 - 6.CONTACT WITHDRAWAL FORCE:3N MIN.
 - 7.TEMPERATURE: -20°C TO +85°C.

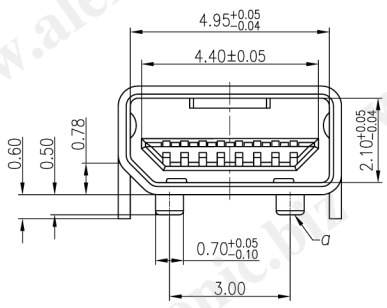
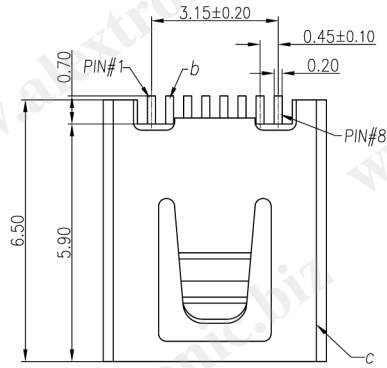
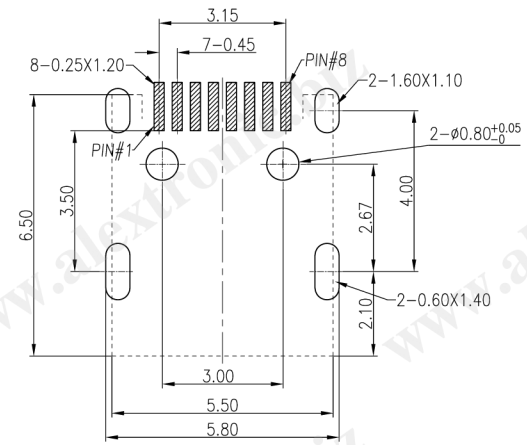

RECOMMEND PCB LAYOUT
TOLERANCE:±0.05mm.

c	SHELL	1	BRASS,T=0.3mm	Au10u",Ni50u"MIN PLATING	
b	TERMINAL	8	PHOSPHOR BRONZE,T=0.15mm	GOLD FLASH PLATING	
a	HOUSING	1	LCP UL94V-0	BLACK	
NO.	DESCRIPTION	Q'TY	MATERIAL	PLATING & COLOR	REMARK

Product Drawing
ALEXTRONIC

UNLESS OTHERWISE SPECIFIED TOLERANCES	SCALE:1/1	UNIT: mm	⊕ ⊖	DWG.NO:
	SIZE: A4	PAGE: 10F1	REV:A01	WI-061-452
DECIMALS: X :±0.5 X.X :±0.3 X.XX :±0.2	ANGLES: X :±2' X.X :±1'	APPROVED BY	CHECKED BY	PREPARED BY
		WYX	PJ	TANGHUI
CUSTOMER COPY				